

# High Voltage High speed IGBT

## IXSH35N140A

Short Circuit SOA Capability

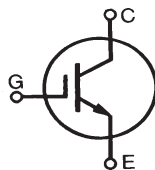

$V_{CES} = 1400V$   
 $I_{C90} = 35A$   
 $V_{CE(sat)} \leq 4.0V$   
 $t_{fi(typ)} = 200ns$

Symbol	Test Conditions	Maximum Ratings	
$V_{CES}$	$T_J = 25^\circ C$ to $150^\circ C$	1400	V
$V_{CGR}$	$T_J = 25^\circ C$ to $150^\circ C$ , $R_{GE} = 1M\Omega$	1400	V
$V_{GES}$	Continuous	$\pm 20$	V
$V_{GEM}$	Transient	$\pm 30$	V
$I_{C25}$	$T_C = 25^\circ C$	70	A
$I_{C90}$	$T_C = 90^\circ C$	35	A
$I_{CM}$	$T_C = 25^\circ C$ , 1ms	140	A
<b>SSOA</b>	$V_{GE} = 15V$ , $T_J = 125^\circ C$ , $R_G = 3\Omega$	$I_{CM} = 70$	A
<b>(RBSOA)</b>	Clamped inductive load	@ $V_{CE} \leq 960$	V
<b><math>t_{SC}</math></b> <b>(SCSOA)</b>	$V_{GE} = 15V$ , $V_{CE} = 840V$ , $T_J = 125^\circ C$ $R_G = 22\Omega$ , non repetitive	10	$\mu s$
$P_C$	$T_C = 25^\circ C$	300	W
$T_J$		-55 ... +150	$^\circ C$
$T_{JM}$		150	$^\circ C$
$T_{stg}$		-55 ... +150	$^\circ C$
$M_d$	Mounting torque	1.13 / 10	Nm/lb.in.
$T_L$	Maximum lead temperature for soldering	300	$^\circ C$
$T_{SOLD}$	1.6mm (0.062 in.) from case for 10s	260	$^\circ C$
<b>Weight</b>		6	g

### TO-247 (IXSH)

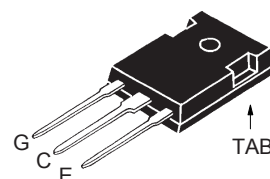

G = Gate      C = Collector  
 E = Emitter    TAB = Collector

### Features

- International standard package JEDEC TO-247AD
- High frequency IGBT with guaranteed Short Circuit SOA Capability
- Fast Fall Time for switching speeds up to 20kHz
- 2nd generation HDMOS™ process
- Low  $V_{CE(SAT)}$   
- for minimum on-state conduction losses
- MOS Gate turn-on  
- drive simplicity

### Applications

- AC motor speed control
- DC servo and robot drive
- Uninterruptible power supplies (UPS)
- Switch-mode and resonant-mode power supplies
- Welding

### Advantages

- Easy to mount with 1 screw (isolated mounting screw hole)
- High power density

Symbol	Test Conditions ( $T_J = 25^\circ C$ , unless otherwise specified)	Characteristic Values		
		Min.	Typ.	Max.
$V_{GE(th)}$	$I_C = 4mA$ , $V_{CE} = V_{GE}$	4.5		6.5 V
$I_{GES}$	$V_{CE} = V_{CES}$ $V_{GE} = 0V$ $T_J = 125^\circ C$			50 $\mu A$ 2.0 mA
$I_{GES}$	$V_{CE} = 0V$ , $V_{GE} = \pm 20V$			$\pm 100$ nA
$V_{CE(sat)}$	$I_C = 35A$ , $V_{GE} = 15V$ , Note 1	3.4	4.0	V

Symbol	Test Conditions ( $T_J = 25^\circ\text{C}$ , unless otherwise specified)	Characteristic Values			
		Min.	Typ.	Max.	
$g_{fs}$	$I_C = 35\text{A}, V_{CE} = 10\text{V}$ , Note 1	16	23	S	
$C_{ies}$	$V_{CE} = 25\text{V}, V_{GE} = 0\text{V}, f = 1\text{MHz}$		3710	pF	
$C_{oes}$			230	pF	
$C_{res}$			73	pF	
$Q_g$	$I_C = 35\text{A}, V_{GE} = 15\text{V}, V_{CE} = 0.5 \cdot V_{CES}$		120	nC	
$Q_{ge}$			32	nC	
$Q_{gc}$			50	nC	
$t_{d(on)}$	<b>Inductive load, <math>T_J = 25^\circ\text{C}</math></b> $I_C = 35\text{A}, V_{GE} = 15\text{V}$ $V_{CE} = 960\text{V}, R_G = 3\Omega$		40	ns	
$t_{ri}$			60	ns	
$t_{d(off)}$			150	300	ns
$t_{fi}$			200	450	ns
$E_{off}$			4.0		mJ
$t_{d(on)}$	<b>Inductive load, <math>T_J = 125^\circ\text{C}</math></b> $I_C = 35\text{A}, V_{GE} = 15\text{V}$ $V_{CE} = 960\text{V}, R_G = 3\Omega$		40	ns	
$t_{ri}$			65	ns	
$E_{on}$			4.0		mJ
$t_{d(off)}$			240		ns
$t_{fi}$			400		ns
$E_{off}$		9.5		mJ	
$R_{thJC}$				0.42 $^\circ\text{C/W}$	
$R_{thCK}$		0.21		$^\circ\text{C/W}$	

### TO-247 (IXSH) Outline

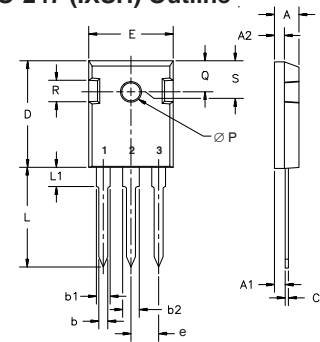

Terminals: 1 - Gate  
2 - Drain  
3 - Source  
Tab - Drain

Dim.	Millimeter		Inches	
	Min.	Max.	Min.	Max.
A	4.7	5.3	.185	.209
A <sub>1</sub>	2.2	2.54	.087	.102
A <sub>2</sub>	2.2	2.6	.059	.098
b	1.0	1.4	.040	.055
b <sub>1</sub>	1.65	2.13	.065	.084
b <sub>2</sub>	2.87	3.12	.113	.123
C	.4	.8	.016	.031
D	20.80	21.46	.819	.845
E	15.75	16.26	.610	.640
e	5.20	5.72	0.205	0.225
L	19.81	20.32	.780	.800
L1		4.50		.177
ØP	3.55	3.65	.140	.144
Q	5.89	6.40	0.232	0.252
R	4.32	5.49	.170	.216
S	6.15	BSC	242	BSC

Notes: 1. Pulse test,  $t \leq 300\mu\text{s}$ ; duty cycle,  $d \leq 2\%$ .

IXYS reserves the right to change limits, test conditions, and dimensions.

IXYS MOSFETs and IGBTs are covered by one or more of the following U.S. patents:

4,835,592	4,931,844	5,049,961	5,237,481	6,162,665	6,404,065 B1	6,683,344	6,727,585	7,005,734 B2	7,157,338B2
4,850,072	5,017,508	5,063,307	5,381,025	6,259,123 B1	6,534,343	6,710,405 B2	6,759,692	7,063,975 B2	
4,881,106	5,034,796	5,187,117	5,486,715	6,306,728 B1	6,583,505	6,710,463	6,771,478 B2	7,071,537	

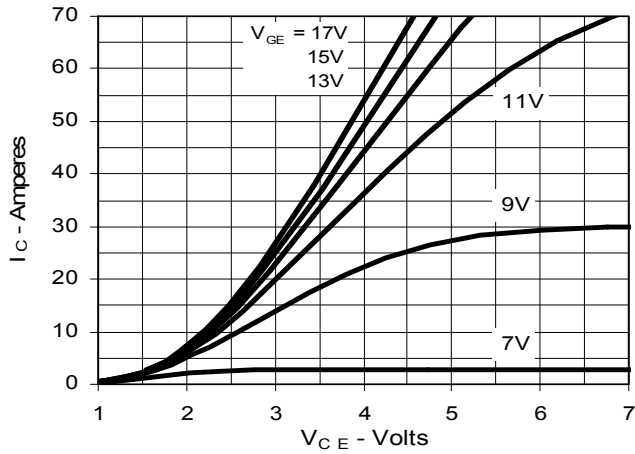
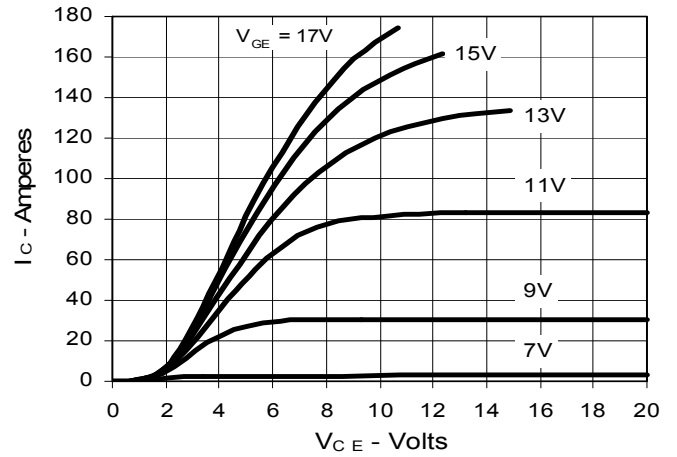
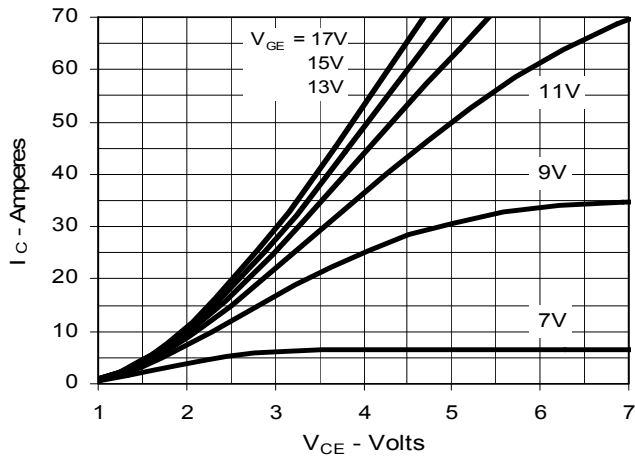
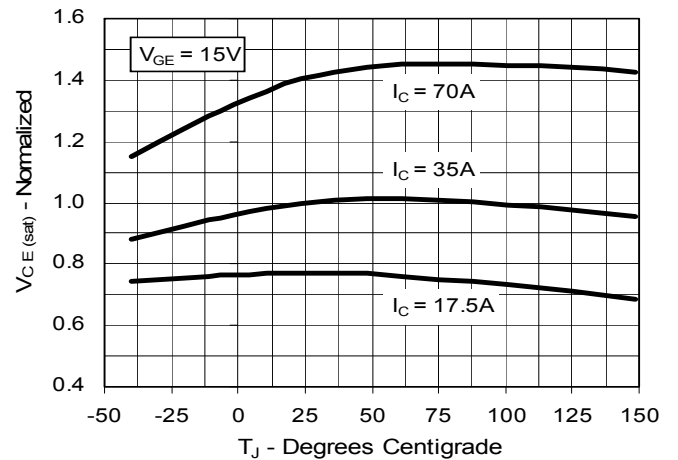
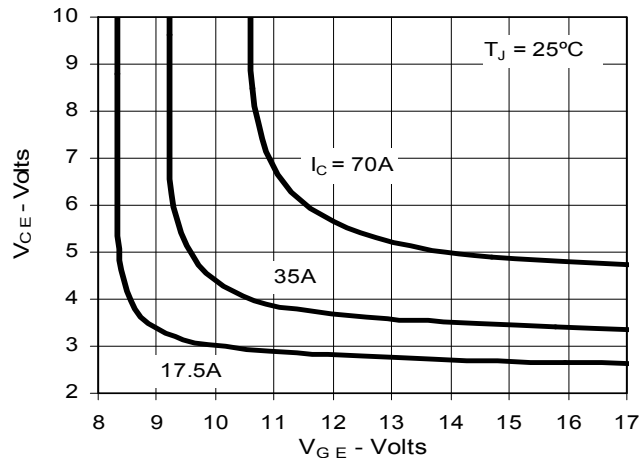
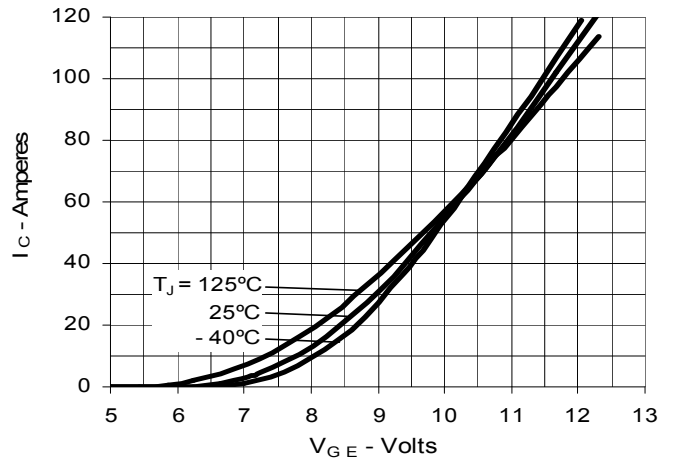
**Fig. 1. Output Characteristics  
@ 25°C**

**Fig. 2. Extended Output Characteristics  
@ 25°C**

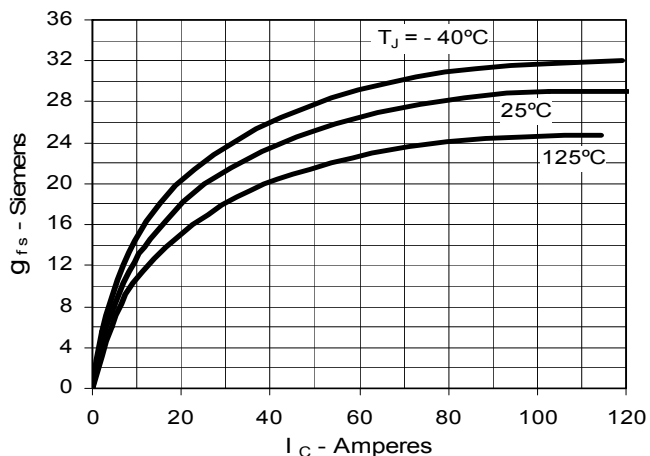
**Fig. 3. Output Characteristics  
@ 125°C**

**Fig. 4. Temperature Dependence of  $V_{CE(sat)}$** 

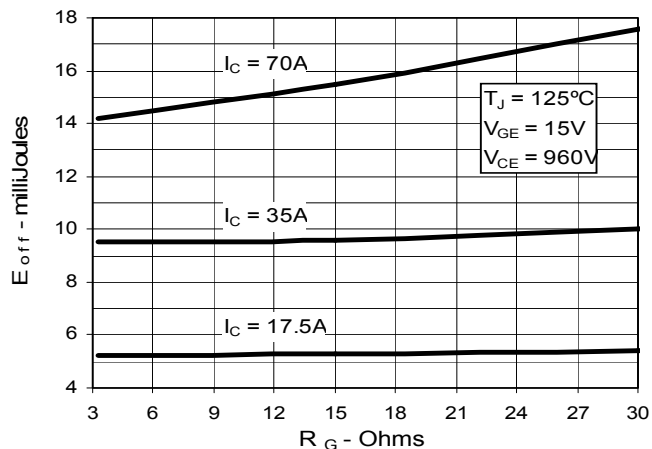
**Fig. 5. Collector-to-Emitter Voltage  
vs. Gate-to-Emitter voltage**

**Fig. 6. Input Admittance**

**Fig. 7. Transconductance**



**Fig. 8. Dependence of  $E_{off}$  on  $R_G$**



**Fig. 9. Dependence of  $E_{off}$  on  $I_C$**

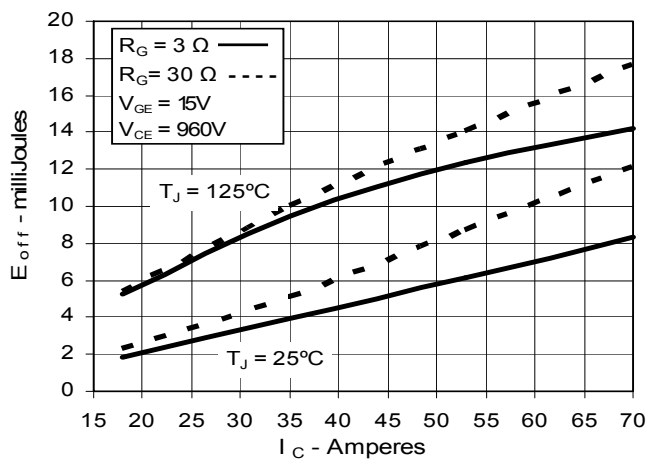

**Fig. 10. Dependence of  $E_{off}$  on Temperature**

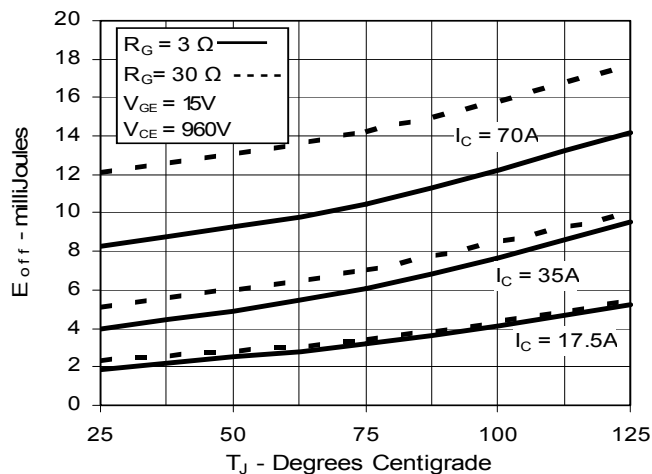

**Fig. 11. Gate Charge**

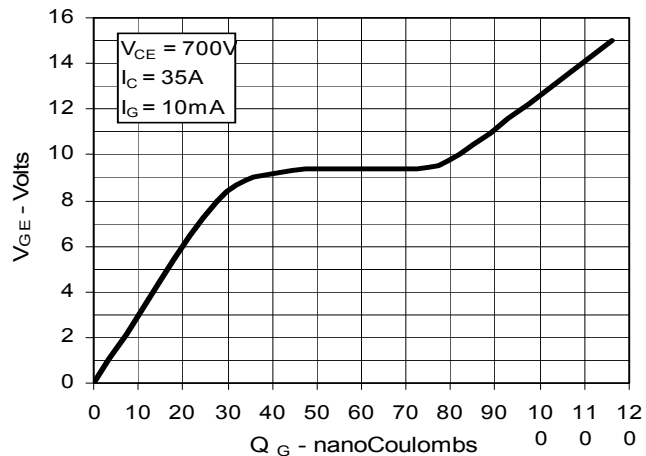

**Fig. 12. Capacitance**

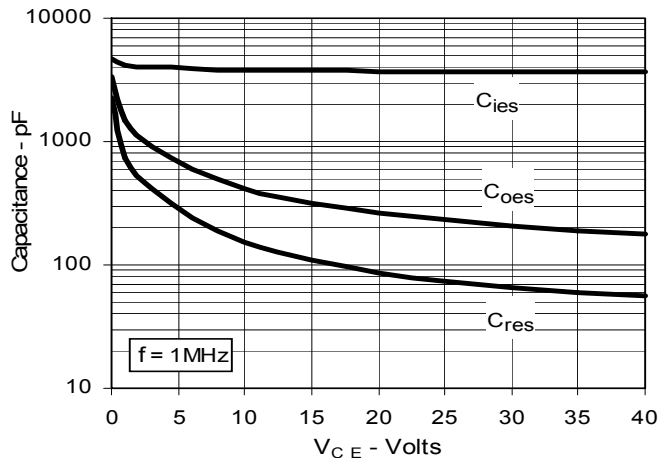

Fig. 13. Maximum Transient Thermal Impedance

